

Progressing cavity pumps Dosing pumps SERIES AEB 2N SERIES AEB 3N

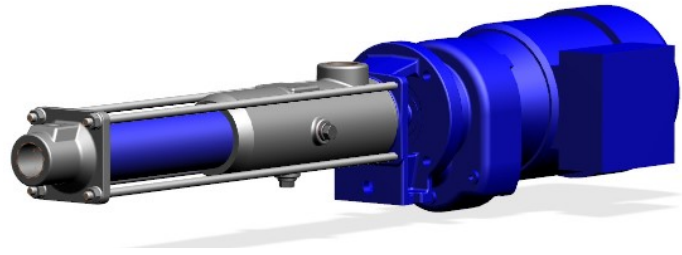

Construction type DE in block-design

Main fields of use

Suitable for pumping and dosing of thin to viscous liquids, neutral or aggressive liquids, undiluted or abrasive liquids, liquids containing gases, liquids prone to foaming, including liquids with fibrous or solid particles.

Primary fields of use in wastewater, water clarification, environmental engineering, chemical and petrochemical industry, the pulp and paper industry, soap and grease, paint and varnish industry, food and beverage industry, plastics- and ceramics industry, agriculture, sugar industry and shipbuilding.

Function

Self-priming rotating displacement pump. Pumping elements are the rotating screw (rotor) and the stationary stator. These two parts contact each other at two points in their cross-section. Viewed along the length of the pumping elements, these points form two sealing lines. As the rotor turns, sealed chambers are created. The content of the chambers is moved continuously in the axial direction from the suction side to the discharge side of the pump. Despite rotation of the rotor, no turbulence results. The consistent chamber volumes eliminate crushing forces and ensure an extremely gentle, almost pulsation-free pumping action.

These pumps achieve a high dosing accuracy, because of their special conveying geometry.

Structural design

The pump and drive are flanged together via a bearing bracket to create a block unit.

Discharge casing, stator, suction casing and bearing bracket are held together with external casing connection screws (tie rods). The suction casing is designed for optimal flow. The stator is vulcanized into a pipe and is equipped on both ends with vulcanized external collars that provide reliable sealing with the suction and discharge casing and protect the stator casing from corrosion.

The exchangeable mechanical seal or stuffing box casing (can be retrofitted to another seal type) is located between the bearing bracket and suction casing.

Dosing pumps of series AEB-DE are designed modular. Discharge casing, suction casing, joint parts, shaft sealing and bearing bracket are the same at every size. By using / eliminating the reducers and by replacing the rotor and stator, the pump can be easily converted to another size while maintaining the above-mentioned components.

Drive torque is transferred over a stub shaft and a joint shaft to the rotor. Both ends of the joint shaft end in liquid-sealed encapsulated pin joints that are designed to be very simple and robust and absorb the rotor's eccentric movement without disturbances.

The sense of rotation is reversible.

Shaft seal

Uncooled, maintenance-free, unbalanced, single-acting mechanical seal according DIN EN 12756 or stuffing box.

Material pairing and construction are adapted to the respective operating conditions.

Technical data

Please refer to the performance curve on page 3 or the separate individual curves for data on pump capacities, permissible speed ranges and required drive output.

				AEB2N	AEB3N
Capacity	Q	l/min	up to	33	14
Pump liquid temperature	t	°C ①	up to	100	
Discharge pressure			up to	12	-
three-stage			up to	-	24
Outlet pressure	p _d	bar ②	up to	25	
Achievable under pressure	p _s	bar ②	up to	0,9	
Viscosity	η	mPa·s ②	up to	28.000	
Permissible proportion of solids	vol	% ②	up to	60	

The performance specifications are intended only as a product / performance overview. Refer to the quotation and order confirmation for precise operational limits.

Maximum permissible grain sizes and fiber lengths

Size	1.3	2.3	5.3	12.2	
max. grain size	mm	1	1	1,8	2
max. fiber length	mm	10	18	17	35

Pump speed must be reduced as the proportion of solids and the grain size increase.

① Depends on pumped liquid and selected elastomers.

② Depends on pump size / design type, speed, pumped liquid.

③ Depends on rotational direction, inlet pressure.

Bearing

The bearing of the drive/stub shaft is provided in the reinforced bearings of the gear- or electric motors, which simultaneously absorb any axial forces.

Drive

The drive can take the form of non-explosion-proof or explosion-proof drive motors, gear motors or adjustable gears.

For specifications and dimensions, see the separate sales documentation, sheet 19-85-0000-009-4.

A major benefit is that connection dimensions are consistent for all drive types and pump sizes. That makes it very easy to convert to a new drive type or pump size at later time.

Installation

AEB-DE dosing pumps can be installed horizontally or vertically. When installed vertically, a “motor down” arrangement is not permitted.

Exchangeability of parts

The components of all progressing cavity pumps are designed to be modular. As a result, a customer who employs several pumps of various series and designs will be able to maintain a simple and cost-effective stock of reserve parts.

Performance curve

Used for rough selection of the pump size and rotational speed for a particular desired flow rate and the type of liquid being pumped. $V_{g,m}$ = current average sliding speed of the rotor in the stator.

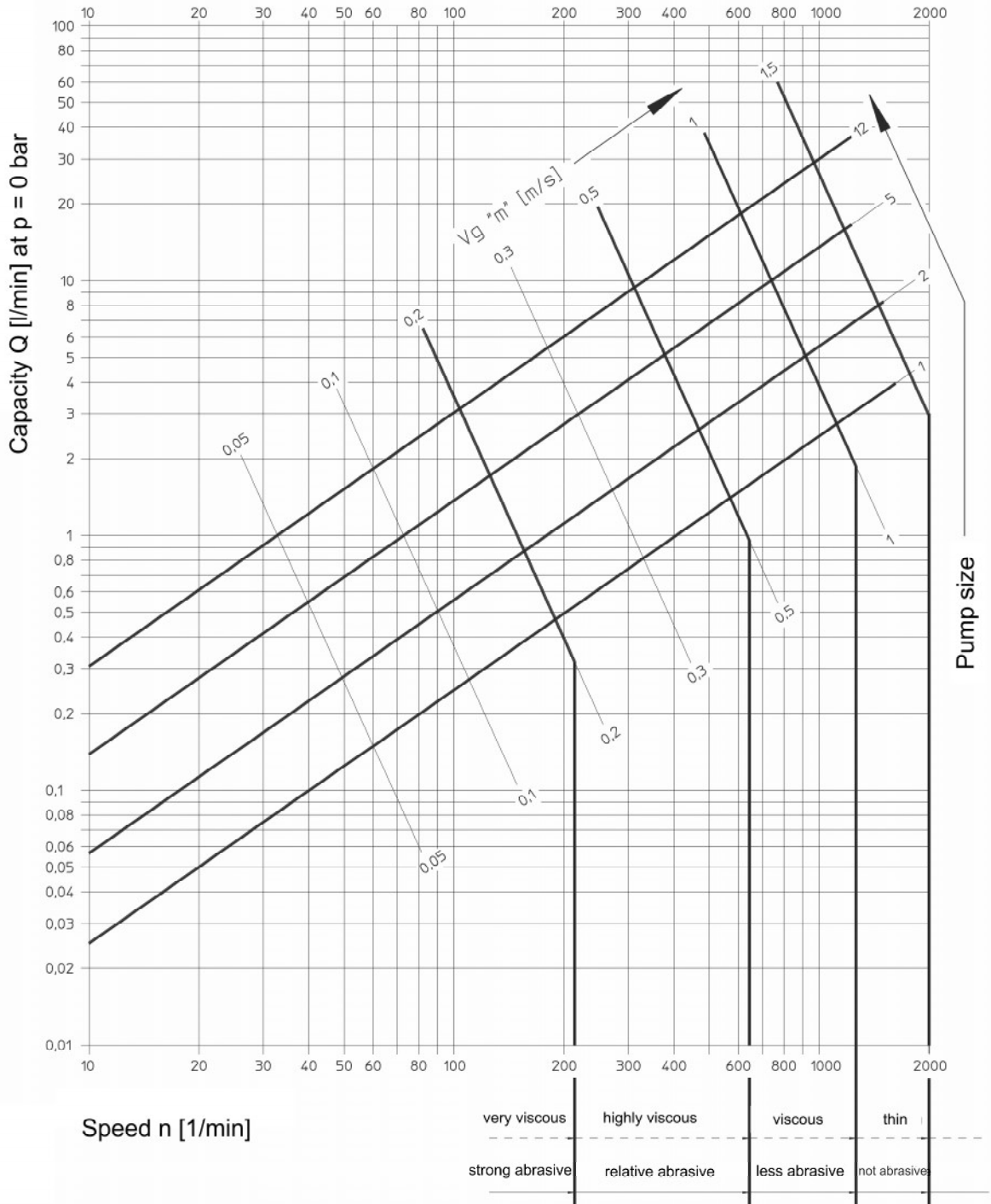

Sizes of series AEB DE. Refer to the separate individual characteristic curves for specifications on the performance range which are not covered by AEB DE series and for more detailed performance data.

Type key

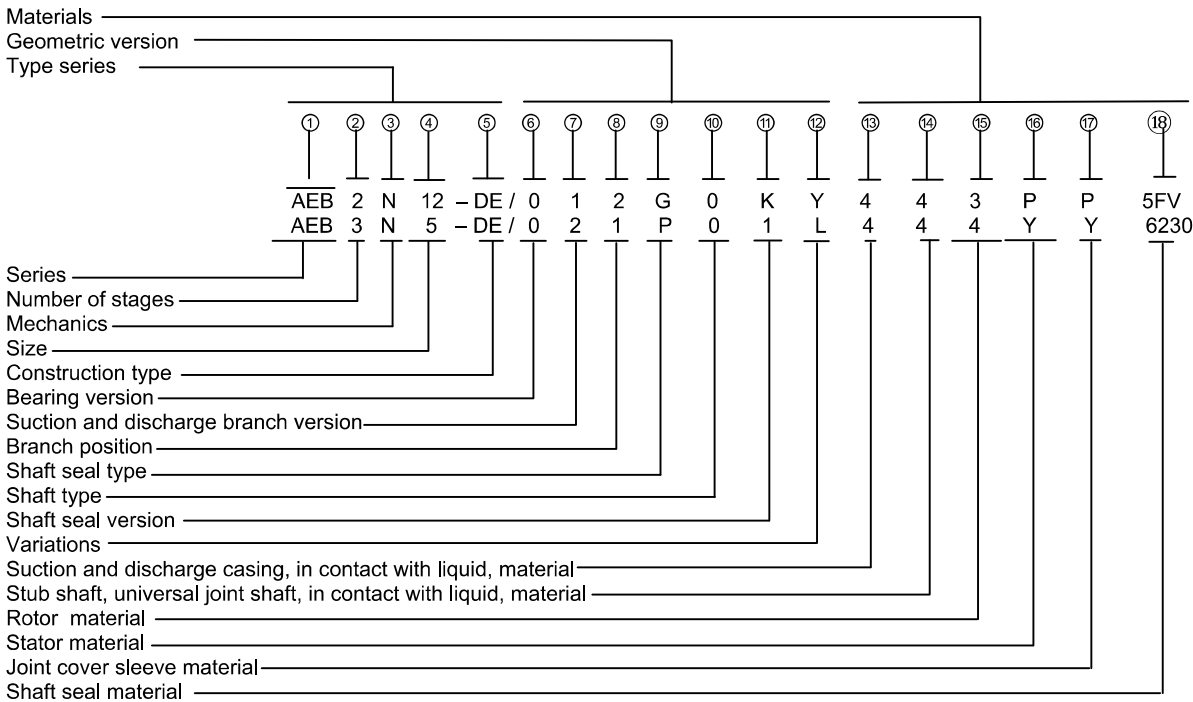

Explanations for type key:

Position in type key	Designation	Design
①	Series	ALLWEILER progressing cavity pump in block design
②	Number of stages	2 = two-stage up to discharge pressure $\Delta p = 12$ bar (for size 12) 3 = three-stage up to discharge pressure $\Delta p = 24$ bar (for size 1, 2, 5)
③	Mechanics	N = sized for discharge pressure $\Delta p = 12$ bar / 24 bar, depending on size
④	Size	two-stage: 12.2 three-stage: 1.3, 2.3, 5.3 The figures indicate theoretical capacity in l/min at $n = 400$ 1/min and $\Delta p = 0$ bar.
⑤	Construction type	DE = Dosing with external bearing
⑥	Bearing version	0 = external bearing in drive unit
⑦	Suction and discharge branch version	1 = DIN-flange – DIN EN 1092 PN25 DN25 2 = Thread connections – DIN EN 10226-1 – Rp 1 (Internal thread) 3 = Thread connections with screwed-in ANSI B16.5 Cl150 NPS 1 – threaded flanges 4 = Thread connections with screwed-in NPT 1" – adapter (Internal thread)
⑧	Branch position	1, 2, 3, 4 – See diagram on page 7 + 8 for arrangement. Arrangement 3 not possible with flanges.
⑨	Shaft seal type	G = Mechanical shaft seal P = Stuffing box
⑩	Shaft type	0 = Shaft without shaft sleeve
⑪	Shaft seal version	Mechanical seal: GOK = Single-acting mechanical seal, DIN EN 12756, K version, U shape; GOQ = Single-acting mechanical seal, DIN EN 12756, K version, U shape with Quench Stuffing box: P01 = Stuffing box in normal version (without seal chamber ring / without flush ring) Shaft diameter at location of shaft seal 25 mm
⑫	Variations	Stators with non-uniform elastomer wall thickness (all qualities) N } Rotor with temp. Tolerance M } that depends on liquid H } temperature T } Y = Hard-chromed ductile rotor L = Stator for thermal dry-running protection

⑬	Suction and discharge casing, in contact with liquid, material	4 = 1.4408		
⑭	Stub shaft, universal joint shaft, in contact with liquid, material	4 = 1.4404/1.4408		
⑮	Rotor material	3 = 1.2436 (only for size 12.2 and 5.3) 4 = 1.4404		
⑯	Stator material	P = Perbunan N Y = Hypalon V = Viton B = Butyl	E = EPDM A = ALLDUR PL = Perbunan light	PA = Perbunan HP = Perbunan/hydrogenated EL = EPDM light
⑰	Joint cover sleeve material	P = Perbunan N V = Viton	Y = Hypalon E = EPDM	PL = Perbunan light B = Butyl
⑱	Shaft seal material	Mechanical Seal:		
		Pairing of sliding materials	Springs and construction material	Secondary seals
		1. position when single seal	2. position	3. position when single seal
		5 = Carbide/carbide highly wear resistant X = Special material	F = 1.4571 / 1.4404 X = Special material	V = Viton X = Special material
		Stuffing box: 5846 = Ramie fiber with PTFE impregnation, asbestos-free 6426 = Aramide endless fiber with PTFE impregnation, asbestos-free 6230 = Graphite-incorporated PTFE with lubricant, asbestos-free		

Sectional drawing and directory of individual parts

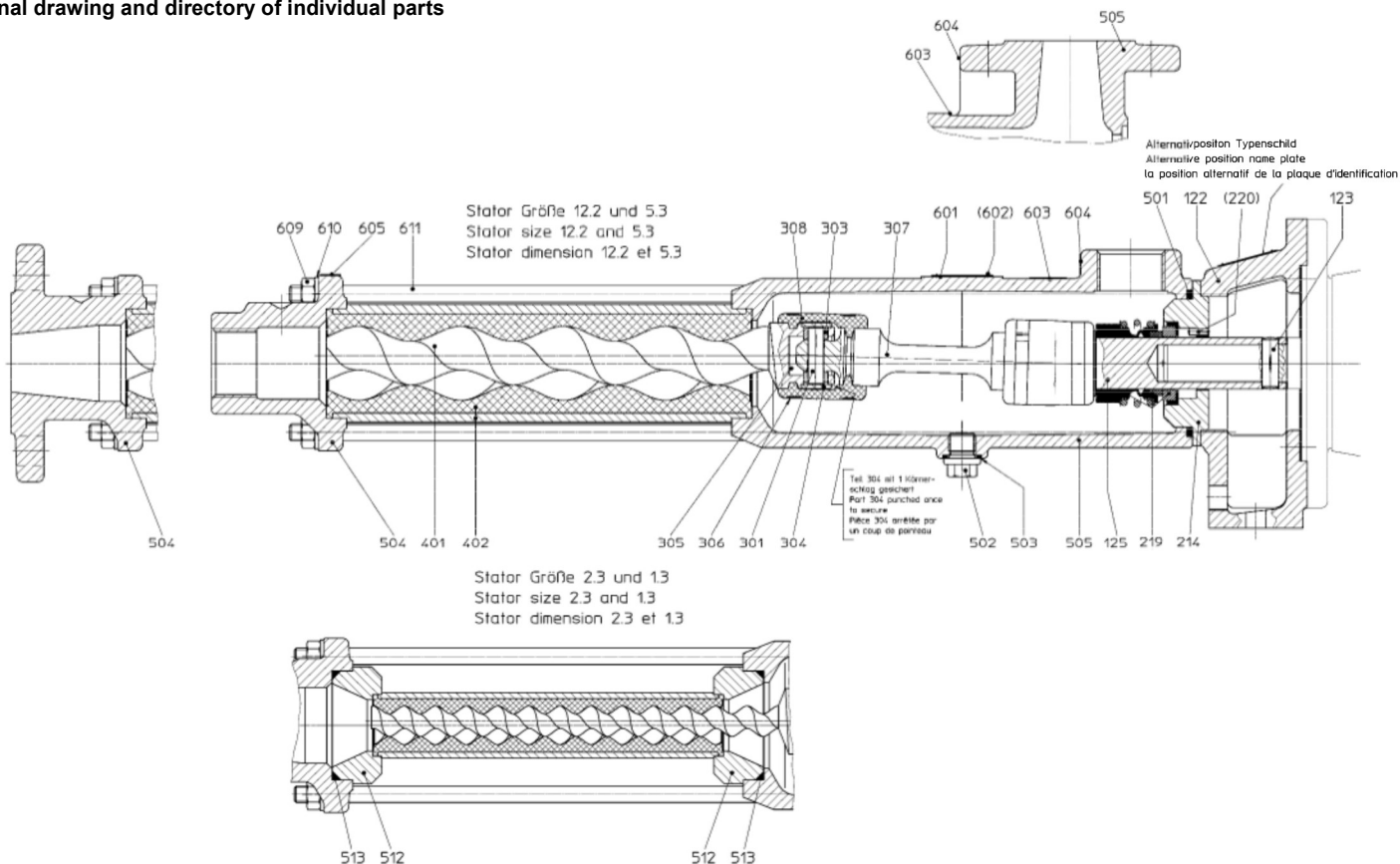

Bearing 0: External reinforced bearings in drive unit
Shaft seal G0K: Permitted pressure at shaft seal $p = -0,5$ to 12 bar (16 bar)

Gleitringdichtung G0Q
 Mechanical seal G0Q
 Garniture mécanique G0Q

einfachwirkend, nicht entlastet,
 drehrichtungsunabhängig, Quench
 single acting non-balanced,
 either direction of rotation, quench
 simple non-equilibrated, à double sens
 de rotation, montés en cul de sac, quench

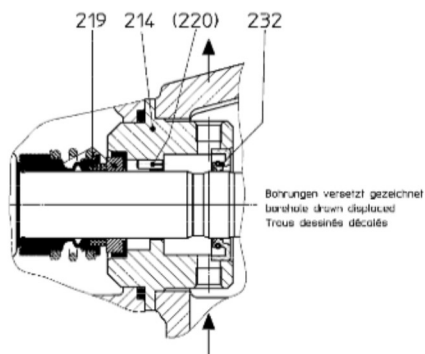

Permitted pressure at shaft seal $p = -0,5$ bis 12 bar (16bar)

Packungsstopfbuchse
 Stuffing box
 Garniture à tresses

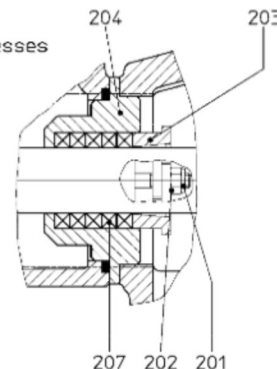

Permitted pressure at shaft seal $p = -0,7$ bis 16 bar.

Part No.	Part name	Part No.	Part name	Part No.	Part name
122	Bearing bracket	301	Joint pin	512	Reducer for Stator
123	Retainer pin	303	Bush for joint pin	513	O-Ring
125	Stub shaft	304	Joint sleeve	601	Nameplate
201	Stud bolt	305	Joint oil	602	Round head grooved pin
202	Self-locking nut	306	Joint clamps	603	Information plate "Start-up"
203	Gland	307	Joint shaft	604	Information plate "Suction"
204	Stuffing box casing	308	Joint cover sleeve	605	Information plate „Discharge“
207	Gland packing	401	Rotor	609	Hexagon nut
214	Mechanical seal housing	402	Stator	610	Washer
219	Mechanical seal	501	O-Ring	611	Tie Rod
220	Locking pin	502	Screw plug		
232	shaft sealing ring	503	Gasket		
		504	Discharge casing		
		505	Suction casing		

Pump dimensions, possible connection positions, weights
Casings with threaded connections

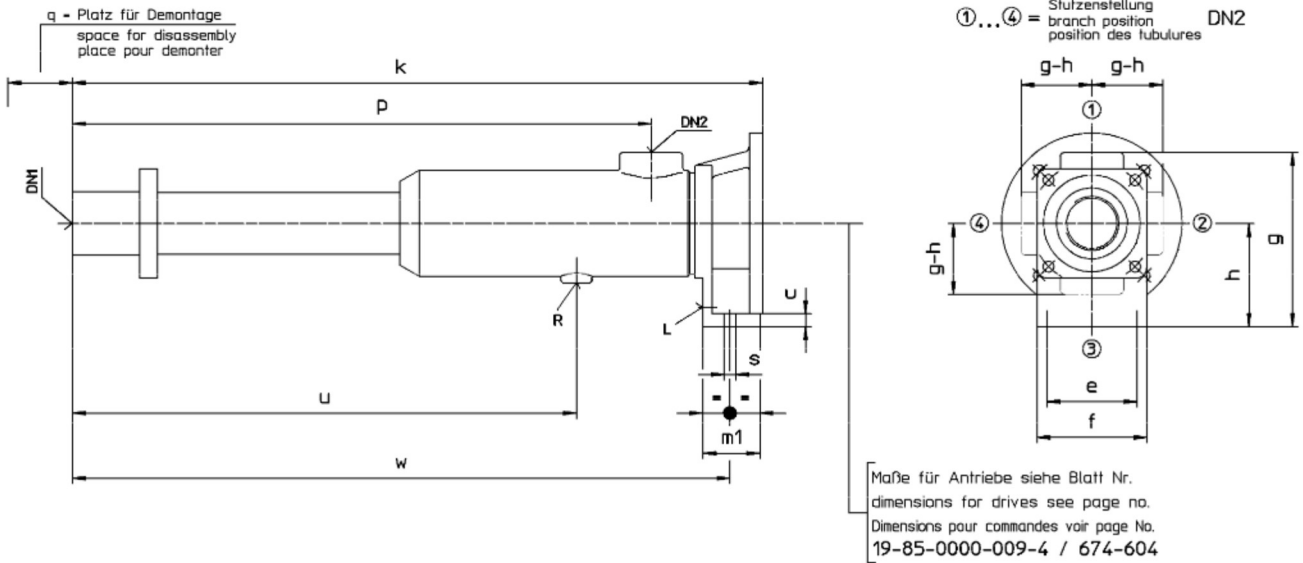

Dimensions in mm
Subject to change.

Direction of rotation: normally left when viewed from drive side,
whereby DN₁ = discharge branch, DN₂ = suction branch,
change of direction possible, then
DN₁ = suction branch, DN₂ = discharge branch

Series Size	Pump dimensions Casing connections: Internal thread DIN EN 10226-1																max. mass kg
	c	e	f	h	m ₁	q	s	DN1	DN2	R ^①	L ^②	g	k	p	u	w	
AEB 3N 0001-DE	10	70	85	80	46	180	9	Rp 1	G 1/4	Rp 1/4	135	535	449	366,5	510	11,5	
AEB 3N 0002-DE																	
AEB 3N 0005-DE																	
AEB 2N 0012-DE																	

① DIN EN ISO 228-1

② DIN EN 10226-1

Max. allowable flange loads acc. EN ISO 14847			
Forces		Moments	
F _(x, y, z) max.	F _(total) max.	M _(x, y, z) max.	M _(total) max.
190 N	270 N	-	-

Series Size	Pump dimensions Casing connections: Internal thread ASME B1.20.1 (with screw-in adapter)																max. mass kg
	c	e	f	h	m ₁	q	s	DN1	DN2	R ^①	L ^②	g	k	p	u	w	
AEB 3N 0001-DE	10	70	85	80	46	180	9	NPT 1	G 1/4	Rp 1/4	177 ±10	577 ±10	491 ±10	408,5 ±10	552 ±10	11,5	
AEB 3N 0002-DE																	
AEB 3N 0005-DE																	
AEB 2N 0012-DE																	

① DIN EN ISO 228-1

② DIN EN 10226-1

Max. allowable flange loads acc. EN ISO 14847			
Forces		Moments	
F _(x, y, z) max.	F _(total) max.	M _(x, y, z) max.	M _(total) max.
190 N	270 N	-	-

Pump dimensions, possible connection positions, weights
Casings with flange connections

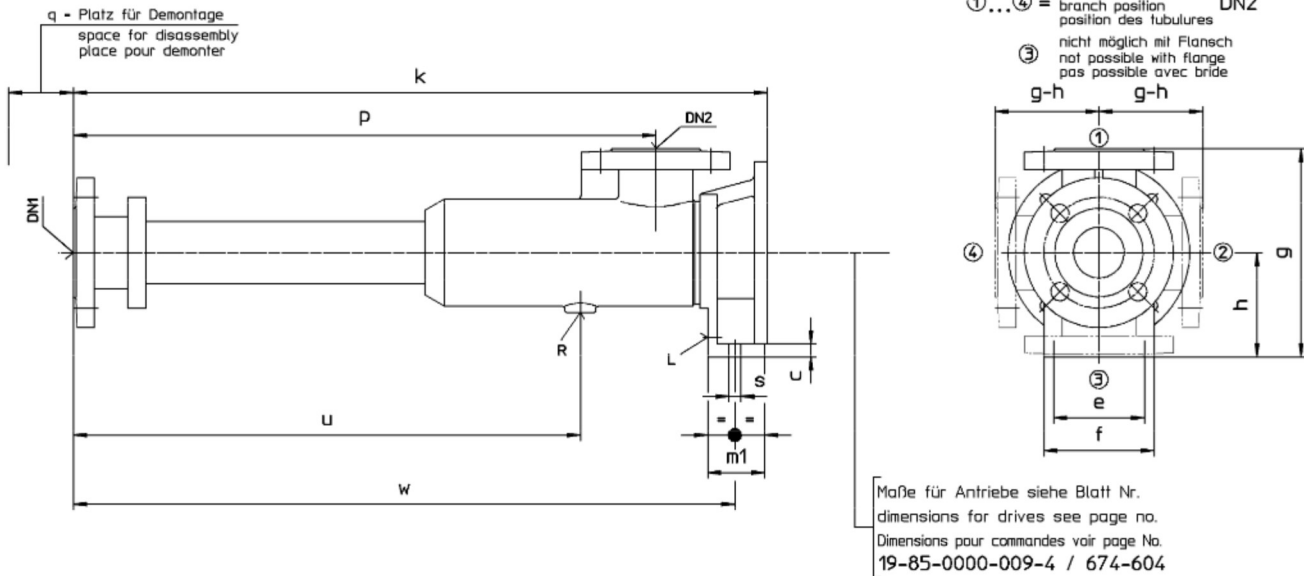

Dimensions in mm
 Subject to change.

Direction of rotation: normally left when viewed from drive side,
 whereby DN₁ = discharge branch, DN₂ = suction branch,
 change of direction possible, then
 DN₁ = suction branch, DN₂ = discharge branch

Series Size	Pump dimensions Casing connections: Flange DIN EN 1092 PN25 DN25															max. Masse kg
	c	e	f	h	m ₁	q	s	DN1	DN2	R ①	L ②	g	k	p	u	
AEB 3N 0001-DE	10	70	85	80	46	180	9	25	G 1/4	Rp 1/4	160	535	449	366,5	510	14,5
AEB 3N 0002-DE																
AEB 3N 0005-DE																
AEB 2N 0012-DE																

① DIN EN ISO 228-1

② DIN EN 10226-1

Max. allowable flange loads acc. EN ISO 14847			
Forces		Moments	
F _(x, y, z) max.	F _(total) max.	M _(x, y, z) max.	M _(total) max.
190 N	270 N	85 Nm	125 Nm

Series Size	Pump dimensions Casing connections: Flange ANSI B16.5 CI150 NPS 1 (Threaded flange)															max. mass kg
	c	e	f	h	m ₁	q	s	DN1	DN2	R ①	L ②	g	k	p	u	
AEB 3N 0001-DE	10	70	85	80	46	180	9	25	G 1/4	Rp 1/4	171 ±10	571 ±10	485 ±10	402,5 ±10	546 ±10	14,5
AEB 3N 0002-DE																
AEB 3N 0005-DE																
AEB 2N 0012-DE																

① DIN EN ISO 228-1

② DIN EN 10226-1

Max. allowable flange loads acc. EN ISO 14847			
Forces		Moments	
F _(x, y, z) max.	F _(total) max.	M _(x, y, z) max.	M _(total) max.
190 N	270 N	-	-

Drive options

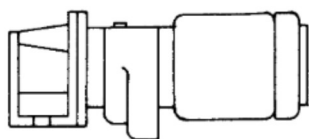

AEB-DE with gear motor

Optional: gear motor and frequency converter
IEC gearbox with and without motor

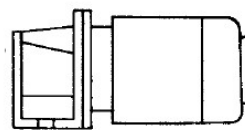

AEB-DE with electric motor

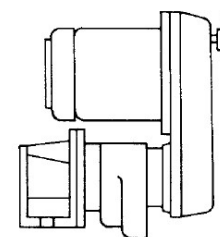

AEB-DE with infinitely adjustable gear box

SERIES AEB 2N Type DE
SERIES AEB 3N Type DE



Subject to technical changes.



ALLWEILER GmbH
P.O. Box 200123 • 46223 Bottrop
Kirchhellener Ring 77-79 • 46244 Bottrop
Germany
Phone +49 (0)2045 966-60
Fax +49 (0)2045 966-679
E-mail: service-ge@allweiler.de
Internet: <http://www.allweiler.com>
GB/2019.08 – Ident-Nr. 256888